

Features

- A Guaranteed Start-Up from less than 0.9 V.
- High Efficiency.
- Low Quiescent Current.
- Less Number of External Components needed.
- Low Ripple and Low Noise.
- Space Saving Packages: MSOP-8L and MSOP-10L.
- MSOP-8L and MSOP-10L: Available in "Green" Molding Compound (No Br, Sb)
- Lead Free Finish / RoHS Compliant (Note 1)

General Description

The AP1601 is a high efficiency step-up DC/DC converter for applications using 1 to 4 NiMH battery cells. Only three external components are required to deliver a fixed output voltage of 3.3V or 5V. The AP1601 starts up from less than 0.9V input with 1mA load. Pulse Frequency Modulation scheme brings optimized performance for applications with light output loading and low input voltages. The output ripple and noise are lower compared with the circuits operating in PSM mode.



The PFM control circuit operating in 100KHz (max.) switching rate results in smaller passive components. The space saving MSOP packages make the AP1601 an ideal choice of DC/DC converter for space conscious applications, like pagers, electronic cameras, and wireless microphones.

Applications

- Pagers
- Cameras
- Wireless Microphones
- Pocket Organizers
- Battery Backup Suppliers
- Portable Instruments

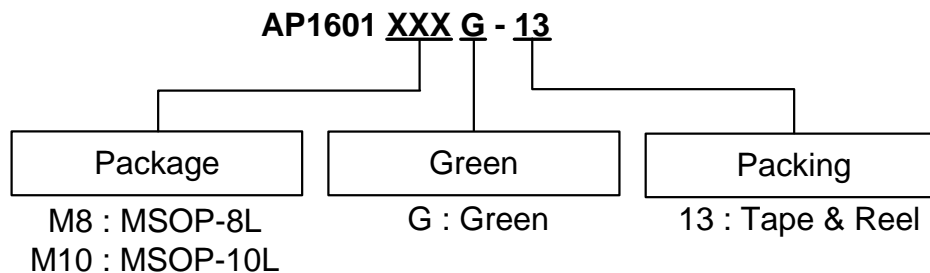
Ordering Information



Device	Package Code	Packaging (Note 2)	13" Tape and Reel	
			Quantity	Part Number Suffix
 AP1601M8G-13	M8	MSOP-8L	2500/Tape & Reel	-13
 AP1601M10G-13	M10	MSOP-10L	2500/Tape & Reel	-13

Notes: 1. EU Directive 2002/95/EC (RoHS). All applicable RoHS exemptions applied, see *EU Directive 2002/95/EC Annex Notes*.
 2. Pad layout as shown on Diodes Inc. suggested pad layout document AP02001, which can be found on our website at <http://www.diodes.com/datasheets/ap02001.pdf>.

Pin Assignment

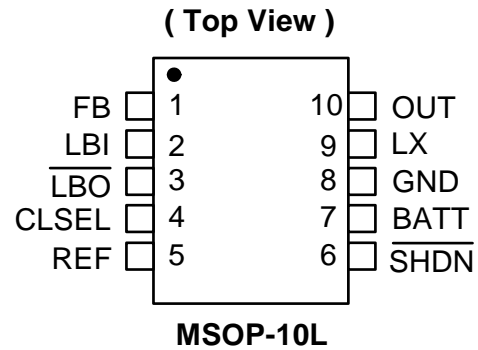
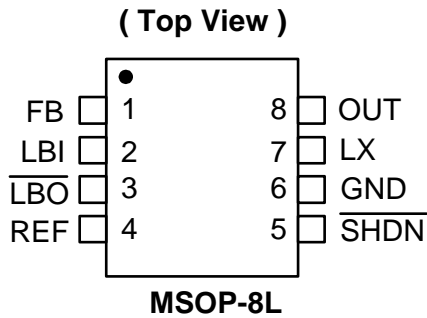

Pin Descriptions

Name	Description
FB	Use a resistor network to set the output voltage from +2.0V to +5.5V. If $FB = V_{OUT}$, $V_{OUT} = 3.3V$ fix voltage If $FB = GND$, $V_{OUT} = 5V$ fix voltage
LBI	Low-Battery Comparator Input. Internally set to trip at +1.30V.
\overline{LBO}	Open-Drain Low-Battery Comparator Output. Connect \overline{LBO} to OUT through a 100k Ω resistor. Output is low when V_{LBI} is <1.2V. \overline{LBO} is high impedance during shutdown.
REF	1.2V Reference Voltage. Bypass with a 0.1 μ F capacitor.
OUT	Power Output. OUT provides bootstrap power to the IC.
LX	N-Channel and P-Channel Power MOSFET Drain
GND	Ground
\overline{SHDN}	Shutdown Input. Drive high (>80% of V_{OUT}) for operating mode. Drive low (<20% of V_{OUT}) for shutdown mode. Connect to OUT for normal operation.
CLSEL	Current-Limit Select Input. CLSEL = OUT sets the current limit to 0.8A. CLSEL = GND sets the current limit to 0.4A.
BATT	Battery Input and Damping Switch Connection. If damping switch is unused, leave BATT unconnected.

Functional Block Diagram

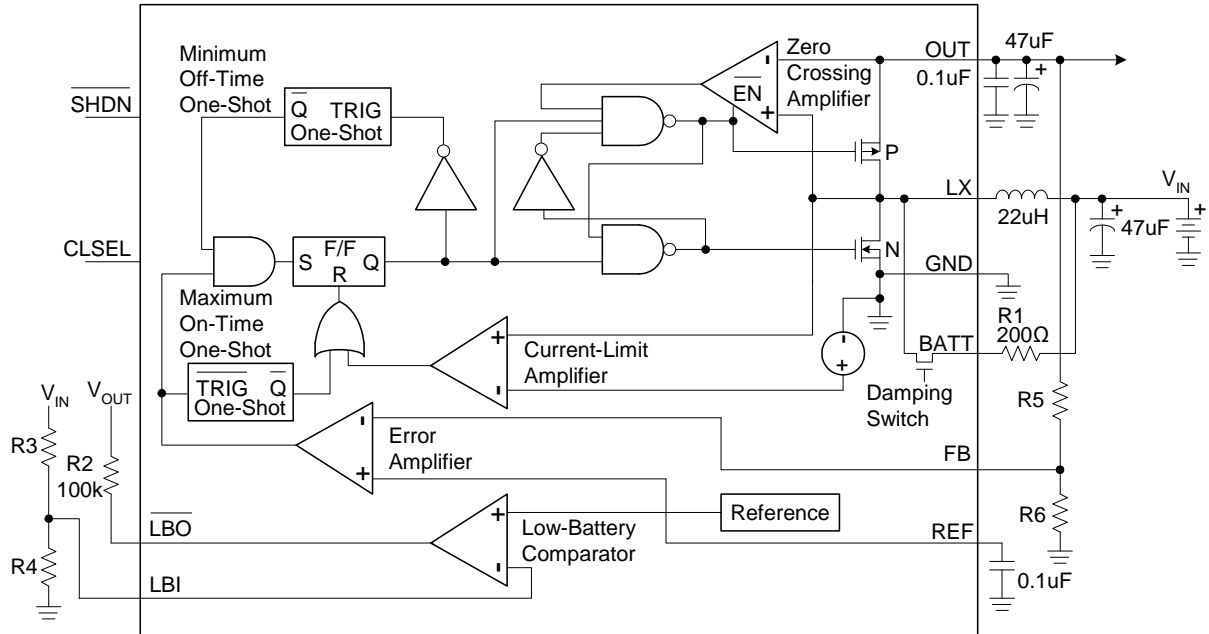

Typical Application Circuit

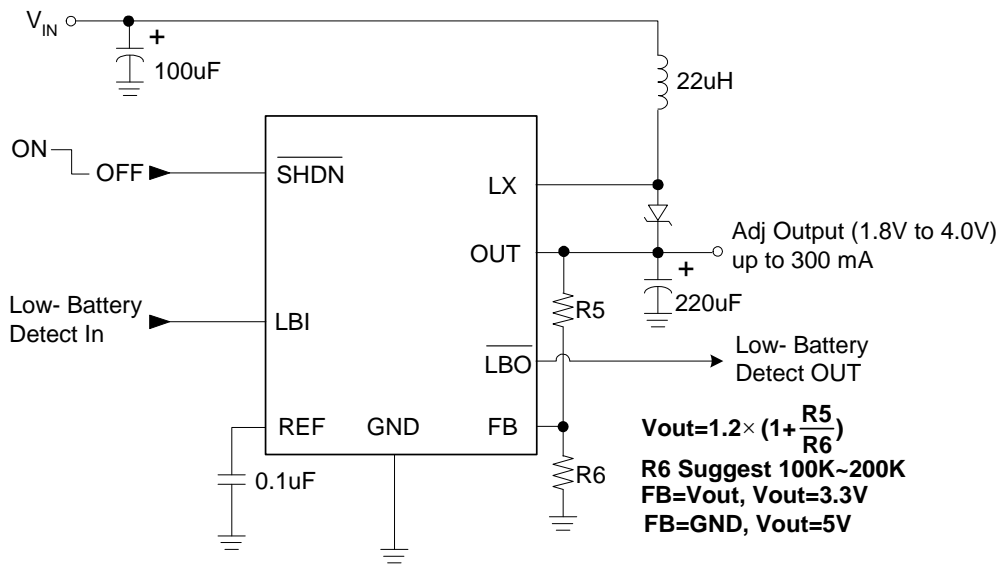

Absolute Maximum Ratings

Symbol	Parameter	Rating	Unit
ESD HBM	Human Body Model ESD Protection	2	KV
ESD MM	Machine Model ESD Protection	200	V
V _{CC}	Supply Voltage (OUT to GND)	-0.3 to 8.0	V
V _{BATT}	Battery Voltage (Batt to GND)	-0.3 to 6.0	V
	LBI, REF, FB, CLSEL to GND	-0.3 to V _{OUT} +0.3	V
V _{SW}	Switch Voltage (LX to GND)	-0.3 to V _{OUT} +0.3	V
I _{OUT}	Output Current (OUT)	-1.5 to +1.5	A
V _{LBO}	LBO to GND	6.0	V
I _{SW}	Switch Current (LX)	-1.5 to +1.5	A
T _J	Operation Junction Temperature Range	-40 to +125	°C
T _{ST}	Storage Temperature Range	-65 to +150	°C

Recommended Operating Conditions

Symbol	Parameter	Min	Max	Unit
V _{IN}	Input Voltage	1.1	5.5	V
I _{OUT}	Output Current	-	1.2	A
T _A	Operating Ambient Temperature	-40	+85	°C

Electrical Characteristics

($V_{BATT} = 2V$, FB = OUT ($V_{OUT} = 3.3V$), $R_L = \infty$, $T_A = 0^\circ C$ to $+85^\circ C$, unless otherwise noted. Typical values are at $T_A = +25^\circ C$.)

Symbol	Parameter	Conditions	Min	Typ.	Max	Unit	
	Minimum Input Voltage		-	0.9	-	V	
V_{IN}	Operating Voltage	$T_A = +25^\circ C$	1.1	-	5.5	V	
	Start-Up Voltage	$T_A = +25^\circ C$, $R_L = 3k\Omega$ (Note 3)	-	0.9	1.1	V	
	Start-Up Voltage Temperature		-	-2	-	mV/ $^\circ C$	
	Output Voltage Range		2	-	5.5	V	
I_{OUT}	Steady-State Output Current (Note 4)	$(V_{OUT} = 3.3V)$	AP1601 (CLSEL=OUT)	300	420	-	mA
			AP1601 (CLSEL=GND)	150	220	-	
		$(V_{OUT} = 5V)$	AP1601 (CLSEL=OUT)	180	285	-	
			AP1601 (CLSEL=GND)	90	130	-	
V_{REF}	Reference Voltage	$I_{REF}=0$	1.176	1.2	1.224	V	
TEMPCO	Reference Voltage Temperature		-	0.024	-	mV/ $^\circ C$	
V_{REF_LOAD}	Reference Voltage Load Regulation	$I_{REF}=0$ to $20\mu A$	-	30	80	mV	
V_{REF_LINE}	Reference Voltage Line Regulation	$V_{OUT}=2V$ to $5.5V$	-	0.08	2.5	mV/V	
	FB, LB1 Input Threshold		1.176	1.2	1.224	V	
$R_{DS(ON)}$	Internal NFET, PFET On-Resistance	$I_{LX}=100mA$	-	0.3	0.6	Ω	
I_{LIM}	LX Switch Current Limit (NFET)	AP1601 MSOP-8L	0.80	1	1.20	A	
		AP1601 MSOP-10L (CLSEL=OUT)	0.80	1	1.20		
		AP1601 MSOP-10L (CLSEL=GND)	0.40	0.50	0.65		
I_{LEAK}	LX Leakage Current	$I_{LX}=0$, $5.5V$; $V_{OUT}=5.5V$	-	0.05	1	μA	
θ_{JA}	Thermal Resistance Junction-to-Ambient	MSOP-8L (Note 5)		118		$^\circ C/W$	
		MSOP-10L (Note 5)		88			
θ_{JC}	Thermal Resistance Junction-to-Case	MSOP-8L (Note 5)		30		$^\circ C/W$	
		MSOP-10L (Note 5)		16			

- Notes:
3. Start-up voltage operation is guaranteed with the addition of a Schottky B0520LW external diode between the input and output.
 4. Steady-state output current indicates that the device maintains output voltage regulation under load.
 5. Test condition for MSOP-8L and MSOP-10L: Devices mounted on 2oz copper, with minimum recommended pad layout on top and bottom layer with thermal vias, double side FR-4 PCB.

Electrical Characteristics (Continued)

($V_{BATT} = 2V$, $R_L = \infty$, $T_A = 0^\circ C$ to $+85^\circ C$, unless otherwise noted. Typical values are at $T_A = +25^\circ C$.)

Symbol	Parameter	Conditions	Min	Typ.	Max	Unit
	Operating Current into OUT	$V_{FB}=1.4V$, $V_{OUT}=3.3V$	-	16	35	μA
	Shutdown Current into OUT	$\overline{SHDN} = GND$	-	0.1	1	μA
	Efficiency	$V_{OUT}=3.3V$, $I_{LOAD}=200mA$	-	90	-	%
		$V_{OUT}=2V$, $I_{LOAD}=1mA$	-	85	-	
t_{ON}	LX Switch On-Time	$V_{FB}=1V$, $V_{OUT}=3.3V$	3	4	7	μs
t_{OFF}	LX Switch Off-Time	$V_{FB}=1V$, $V_{OUT}=3.3V$	0.8	1	1.2	μs
I_{FB}	FB Input Current	$V_{FB}=1.4V$	-	0.03	50	nA
I_{LBI}	LBI Input Current	$L_{LBI}=1.4V$	-	1	50	nA
I_{CLSEL}	CLSEL Input Current	AP1601, $CLSEL=OUT$	-	1.4	3	μA
I_{SHDN}	\overline{SHDN} Input Current	$V_{\overline{SHDN}}=0$ or V_{OUT}	-	0.07	50	nA
	\overline{LBO} Low Output Voltage	$L_{LBI}=0$, $I_{SINK}=1mA$	-	0.2	0.4	V
$I_{\overline{LBO}}$	\overline{LBO} Off Leakage Current	$V_{\overline{LBO}}=5.5V$, $L_{LBI}=5.5V$	-	0.07	1	μA
	Damping Switch Resistance	AP1601, $V_{BATT}=2V$	-	88	150	Ω
V_{IL}	\overline{SHDN} Input Voltage		-	-	$0.2 V_{OUT}$	V
V_{IH}			$0.8 V_{OUT}$	-	-	
V_{IL}	CLSEL Input Voltage		-	-	$0.2 V_{OUT}$	V
V_{IH}			$0.8 V_{OUT}$	-	-	

Typical Performance Characteristics

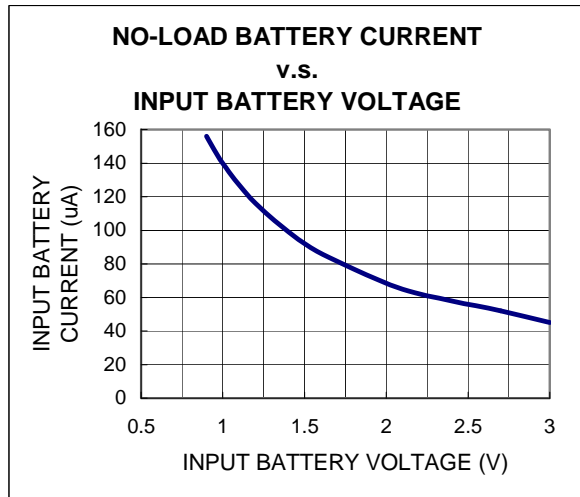
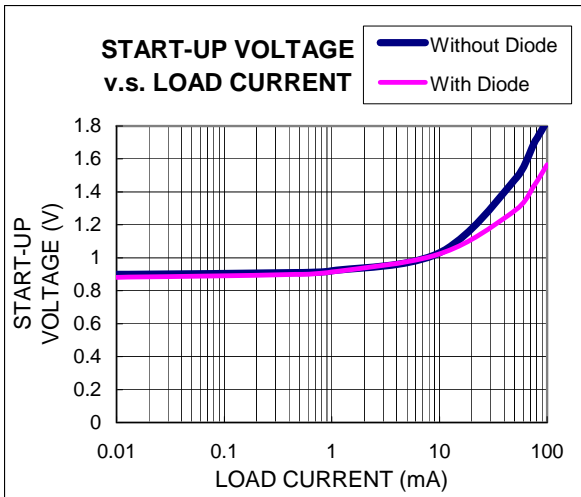
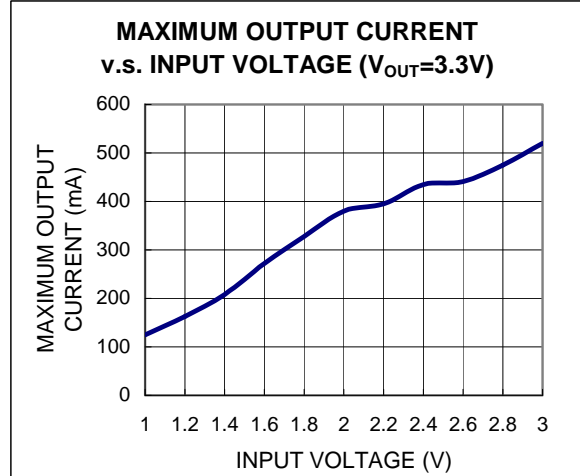
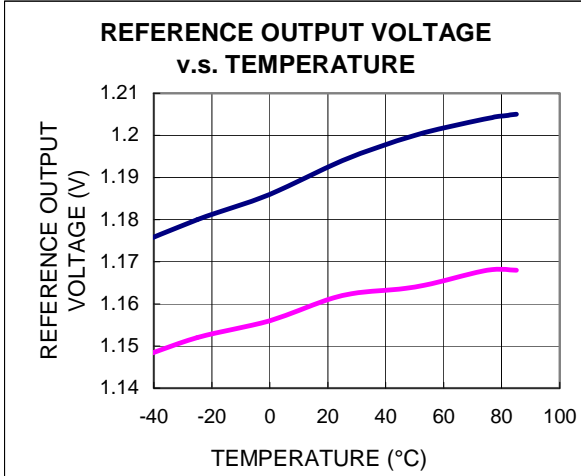

Typical Performance Characteristics (Continued)

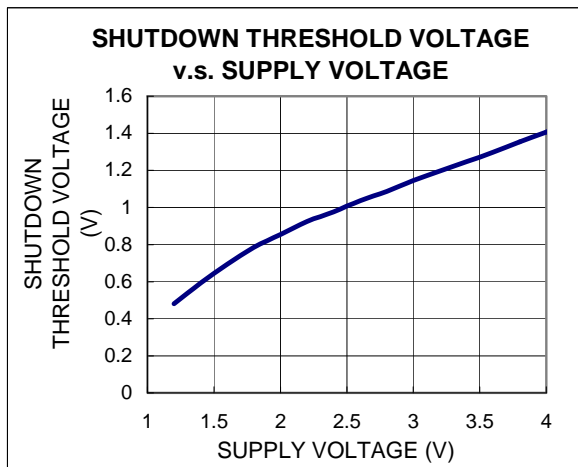
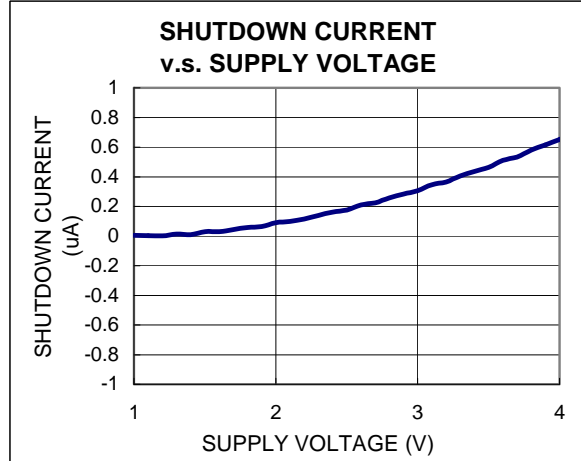
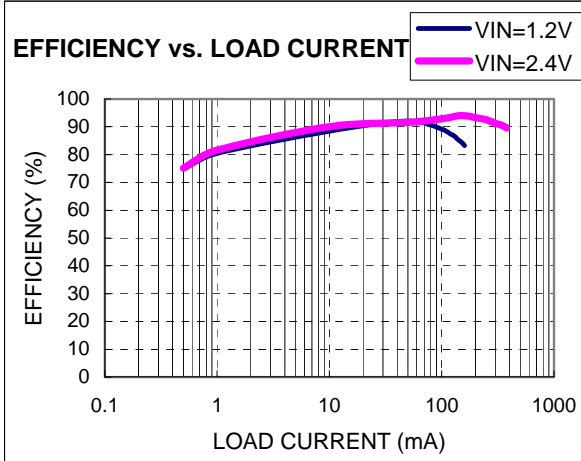

Functional Description

General Description

AP1601 PFM (pulse frequency modulation) converter IC series combine a switch mode converter, N-channel power MOSFET, precision voltage reference, and voltage detector in a single monolithic device. They offer both extreme low quiescent current, high efficiency, and very low gate threshold voltage to ensure start-up with low battery voltage (0.9V typ.). Designed to maximize battery life in portable products, and minimize switching losses by only switching as needed service the load. PFM converters transfer a discrete amount of energy per cycle and regulate the output voltage by modulating switching frequency with the constant turn-on time. Switching frequency depends on load, input voltage, and inductor value, and it can range up to 100KHz. The SW on resistance is typically 1 to 1.5W to minimize switch losses. When the output voltage drops, the error comparator enables 100KHz oscillator that turns on the MOSFET around 7.5us and 2.5ms off time. Turning on the MOSFET allows inductor current to ramp up, storing energy in a magnetic field and when MOSFET turns off that force inductor current through diode to the output capacitor and load. As the stored energy is depleted, the current ramp down until the diode turns off. At this point, inductor may ring due to residual energy and stray capacitance. The output capacitor stores charge when current flowing through the diode is high, and release it when current is low, thereby maintaining a steady voltage across the load. As the load increases, the output capacitor discharges faster and the error comparator initiates cycles sooner, increasing the switching frequency. The maximum duty cycle ensure adequate time for energy transfer to output during the second half each cycle. Depending on circuit, PFM converter can operate in either discontinuous mode or continuous conduction mode. Continuous conduction mode means that the inductor current does not ramp to zero during each cycle.

Diode Selection

Speed, forward drop, and leakage current are the three main considerations in selecting a rectifier diode. Best performance is obtained with Schottky rectifier diode, such as 1N5819. Motorola makes B0520LW in surface mount. For lower output power a 1N4148 can be used although efficiency and start up voltage will suffer substantially.

Inductor Selection

To operate as an efficient energy transfer element, the inductor must fulfill three requirements. First, the inductance must be low enough for the inductor to store adequate energy under the worst case condition of minimum input voltage and switch ON time. Second, the inductance must also be high enough so maximum current rating of AP1601 and inductor are not exceed at the other worst case condition of maximum input voltage and ON time. Lastly, the inductor must have sufficiently low DC resistance so excessive power is not lost as heat in the windings. But unfortunately this is inversely related to physical size. Minimum and Maximum input voltage, output voltage and output current must be established before and inductor can be selected.

Capacitor Selection

A poor choice for a output capacitor can result in poor efficiency and high output ripple. Ordinary aluminum electrolyzers, while inexpensive may have unacceptably poor ESR and ESL. There are low ESR aluminum capacitors for switch mode DC-DC converters which work much better than general propose unit. Tantalum capacitors provide still better performance at more expensive. OS-CON capacitors have extremely low ESR in a small size. If capacitance is reduced, output ripple will increase. Most of the input supply is supplied by the input bypass capacitor. The capacitor voltage rating should be at least 1.25 times greater than a maximum input voltage.

Marking Information

(1) MSOP-8L

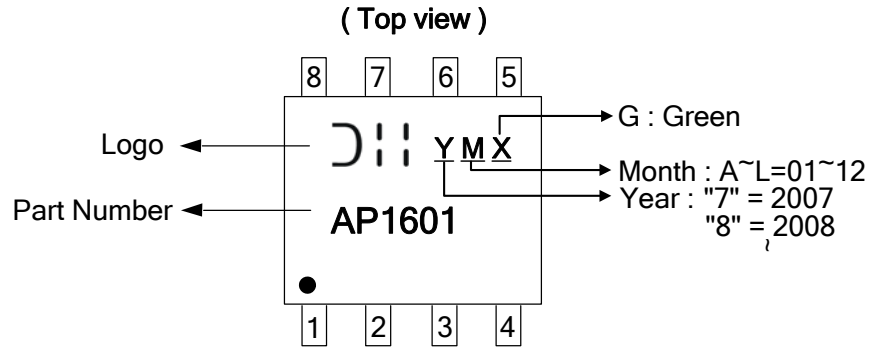

(2) MSOP-10L

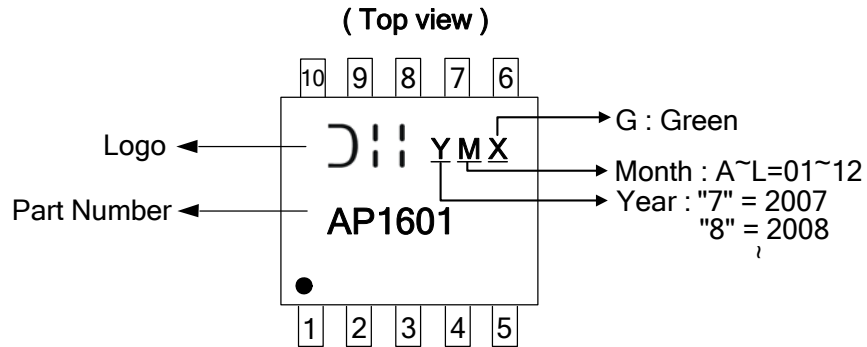

Package Information (All Dimensions in mm)

(1) Package Type: MSOP-8L

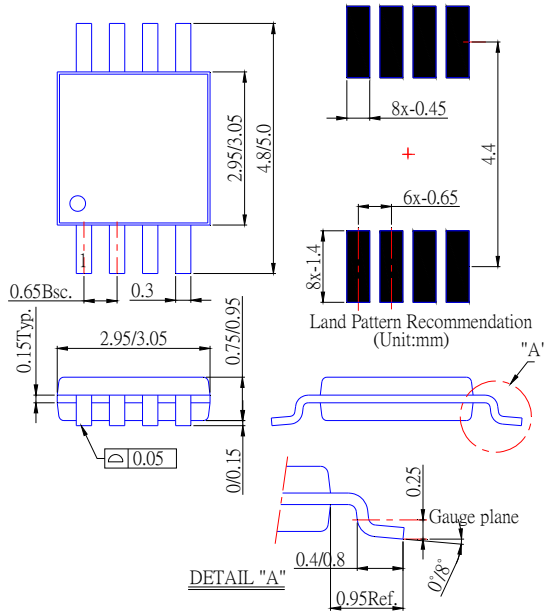

(2) Package Type: MSOP-10L

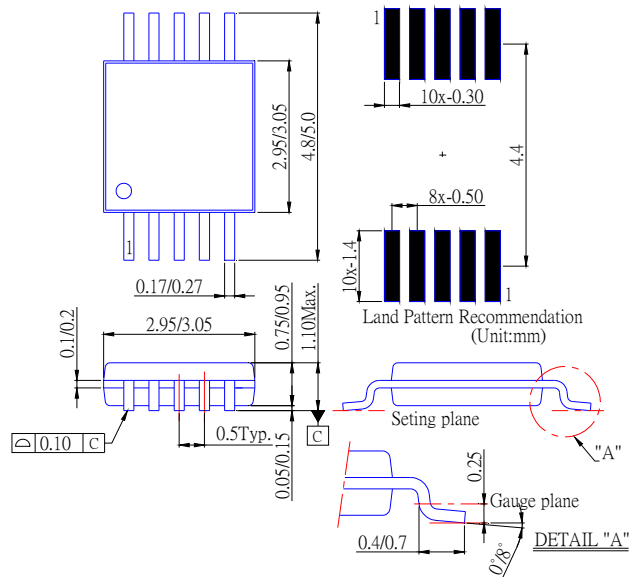

IMPORTANT NOTICE

Diodes Incorporated and its subsidiaries reserve the right to make modifications, enhancements, improvements, corrections or other changes without further notice to any product herein. Diodes Incorporated does not assume any liability arising out of the application or use of any product described herein; neither does it convey any license under its patent rights, nor the rights of others. The user of products in such applications shall assume all risks of such use and will agree to hold Diodes Incorporated and all the companies whose products are represented on our website, harmless against all damages.

LIFE SUPPORT

Diodes Incorporated products are not authorized for use as critical components in life support devices or systems without the expressed written approval of the President of Diodes Incorporated.